

## 7 SPLIT STAR

### FORGED STEEL BALL VALVES



PED 97/23 EC

**CE** 0038

Certificate N°: RPS 0160304/01

ATEX 94/9 CE



Tech. File N° ST01 ATEX



6D-0233



TYPE APPROVED



FLANGED PN 16 - 25 - 40  
Face to face according to EN 558-1 Basic Series 14  
on request according to EN 558-1 Basic Series 1

FLANGED ASME 150  
Face to face according to ASME B16.10  
Flanged according to ASME B16.5

FLANGED ASME 300  
Face to face according to ASME B16.10  
Flanged according to ASME B16.5

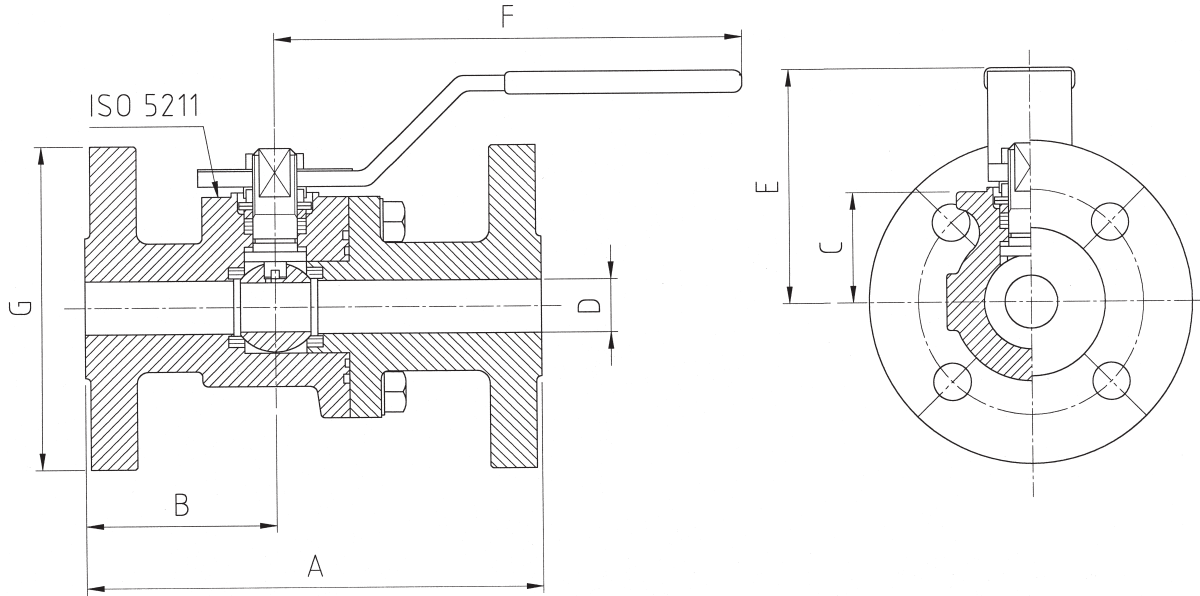

PN 16-25-40 SERIE 14 FULL BORE									
VALVE DN	DIMENSIONS mm							ISO 5211	WEIGHT KG
	A	B	C	D	E	F	G		
15	115	49	27	15	70	152	95	F03	1,4
20	120	50	33,5	20	80	193	105	F04	3,2
25	125	53	38	25	92	193	115	F04	4,5
32	130	56,5	43,5	32	100	225	140	F05	6,2
40	140	58,5	47,5	40	113	225	150	F05	7,5
50	150	63	58,5	50	118	225	165	F05	10,5
65	170	72,5	70	65	135	360	185	F07	15
80	180	77	87,5	80	150	420	200	F07	20
100	300*	90	110	100	190	420	235	F07	45
150**	350*	170	170	150	263	700	300	F10	65

\* Face to Face according to EN-558-1 SERIE 15

PN 16-25-40 SERIE 15 REDUCED BORE									
VALVE DN	DIMENSIONS mm							ISO 5211	WEIGHT KG
	A	B	C	D	E	F	G		
150	350	105	110	100	190	420	300	F07	57
200**	400	115	170	150	263	700	375	F10	76

\*\* Available only for class PN 16-25

ASME/ANSI 150 FULL BORE										
VALVE SIZE	DIMENSIONS mm/inch							ISO 5211	WEIGHT	
	A	B	C	D	E	F	G		KG	LBS
DN 15	108	45,5	27	15	70	152	89,5	F03	1,3	2,9
inch 1/2"	4.1/4"	1.3/4"	1.1/8"	0.6"	2.3/4"	6"	3.1/2"			
DN 20	117,5	50	33,5	20	80	193	98,5	F04	3	6,7
inch 3/4"	4.5/8"	2"	1.1/4"	0.8"	3.1/8"	7.1/2"	3.7/8"			
DN 25	127	53	38	25	92	193	108	F04	4,5	10
inch 1"	5"	2.1/8"	1.1/2"	1"	3.5/8"	7.1/2"	4.1/4"			
DN 32	140	56,5	43,5	32	100	225	117,5	F05	6	13,3
inch 1.1/4"	5.1/2"	2.1/4"	1.3/4"	1.25"	4"	8.7/8"	4.5/8"			
DN 40	165	58,5	47,5	40	113	225	127	F05	7,5	16,7
inch 1.1/2"	6.1/2"	2.3/8"	1.7/8"	1.6"	4.1/2"	8.7/8"	5"			
DN 50	178	63	58,5	50	118	225	152,5	F05	10,5	23,3
inch 2"	7"	2.1/2"	2.1/4"	1.96"	4.5/8"	8.7/8"	6"			
DN 65	190,5	72,5	70	65	135	360	178	F07	15	33,3
inch 2.1/2"	7.1/2"	2.7/8"	2.3/4"	2.55"	5.3/8"	14.1/8"	7"			
DN 80	203	77	87,5	80	150	420	190,5	F07	20	44,4
inch 3"	8"	3"	3.1/2"	3.15"	5.7/8"	16.9/16"	7.1/2"			
DN 100	228,5	90	110	100	190	420	228,5	F07	50	111
inch 4"	9"	3.9/6"	4.5/16"	3.94"	7.1/2"	16.9/16"	9"			
DN 150	394	170	151	150	263	700	279,5	F10	80	177,6
inch 6"	15.1/2"	6.11/16"	5.15/16"	5.90"	10.3/8"	27.9/16"	11"			

PN 16-25-40 SERIE 1 FULL BORE									
VALVE DN	DIMENSIONS mm							ISO 5211	WEIGHT KG
	A	B	C	D	E	F	G		
15	130	49	27	15	70	152	95	F03	1,5
20	150	50	33,5	20	80	193	105	F04	3,4
25	160	53	38	25	92	193	115	F04	4,9
32	180	56,5	43,5	32	100	225	140	F05	6,8
40	200	58,5	47,5	40	113	225	150	F05	8,5
50	230	63	58,5	50	118	225	165	F05	12
65	290	72,5	70	65	135	360	185	F07	18,5
80	310	77	87,5	80	150	420	200	F07	26
100	350	90	110	100	190	420	235	F07	54
150**	480	170	170	150	263	700	300	F10	76

PN 16-25-40 SERIE 1 REDUCED BORE									
VALVE DN	DIMENSIONS mm							ISO 5211	WEIGHT KG
	A	B	C	D	E	F	G		
150	480	240	110	100	190	420	300	F07	68
200**	600	300	170	150	263	700	375	F10	83

ASME/ANSI 150 REDUCED BORE										
VALVE SIZE	DIMENSIONS mm/inch							ISO 5211	WEIGHT	
	A	B	C	D	E	F	G		KG	LBS
DN 150	394	197	110	100	190	420	279,5	F07	60	133,2
inch 6"	15.1/2"	7.3/4"	4.5/16"	3.94"	7.1/2"	16.9/16"	11"			
DN 200	457	228,5	151	150	263	700	342,9	F10	95	210,9
inch 8"	18"	9"	5.15/16"	5.90"	10.3/8"	27.9/16"	13.1/2"			

ASME/ANSI 300 FULL BORE										
VALVE SIZE	DIMENSIONS mm/inch							ISO 5211	WEIGHT	
	A	B	C	D	E	F	G		KG	LBS
DN 100	305	90	110	100	190	420	254	F07	65	144,3
inch 4"	9"	3.9/16"	4.5/16"	3.94"	7.1/2"	16.9/16"	10"			

ASME/ANSI 300 REDUCED BORE										
VALVE SIZE	DIMENSIONS mm/inch							ISO 5211	WEIGHT	
	A	B	C	D	E	F	G		KG	LBS
DN 150	403	202	110	100	190	420	317,5	F07	83	184,3
inch 6"	15.1/2"	7.15/16"	4.5/16"	3.94"	7.1/2"	16.9/16"	12.1/2"			



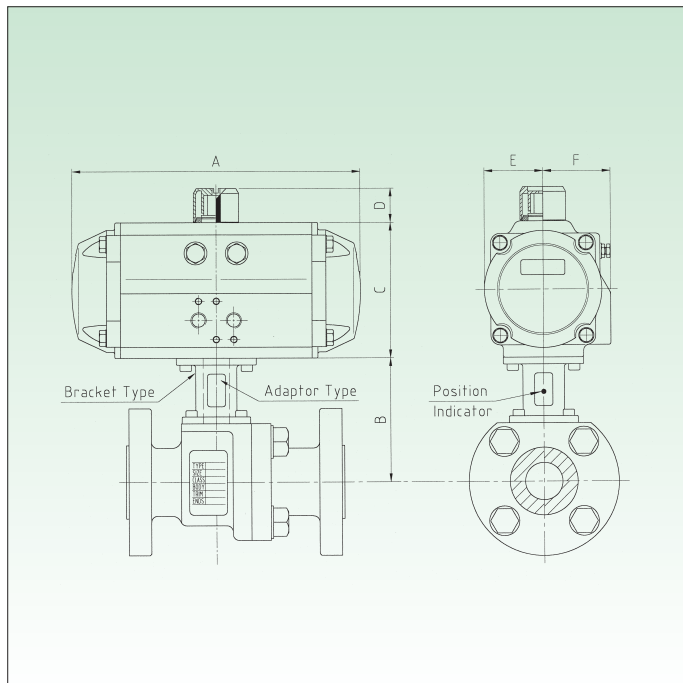
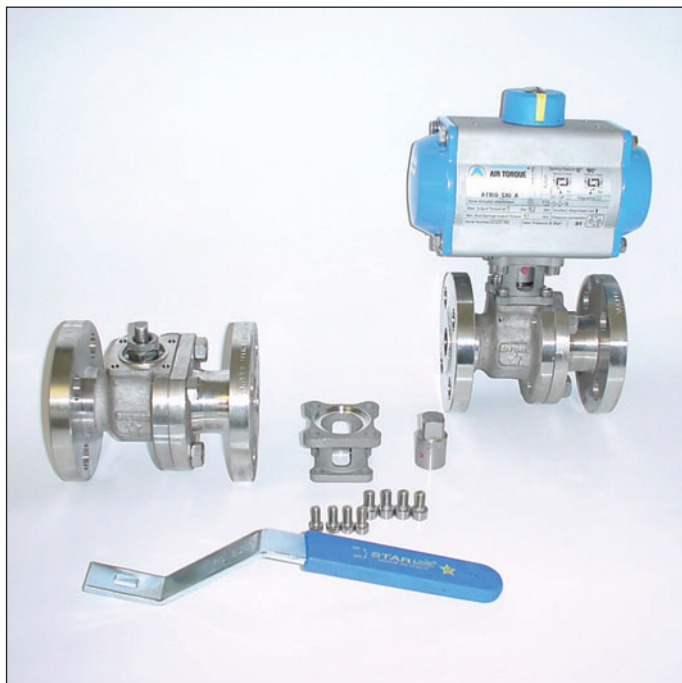

**HOW TO TRANSFORM A MANUAL OPERATED VALVE IN AUTOMATED VALVES**

- 1 - Take out the handle nut (part. no 2A)
- 2 - Take out the lever (part.no.1)
- 3 - Fit again the handle nut (part no. 2A)

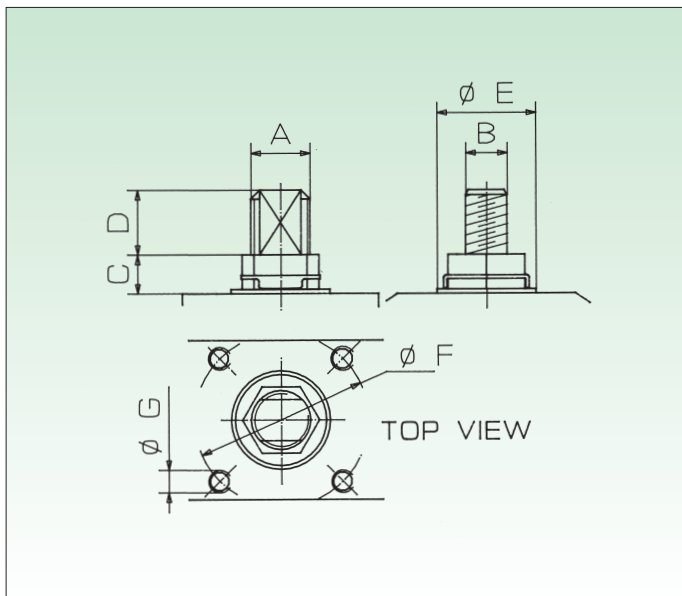

**DIMENSIONS AND TORQUE TO SELECT ACTUATOR SUITABLE FOR STARLINE BALL VALVES**

VALVE SIZE		A	B	C	D	Ø E	Ø F	G	ISO 5211
FULL BORE	RED. BORE	mm	mm	mm	mm	mm	mm	mm	
1/2"	15	M10x1	5.5	6	5.5	25	36	M5x8	F03
3/4"	20	M12x1.25	7.5	12.5	7	30	42	M5x8	F04
1"	25	M12x1.25	7.5	12.5	7	30	42	M5x8	F04
1.1/4"	32	M15x1.5	8.9	14	13	35	50	M6x10	F05
1.1/2"	40	M15x1.5	8.9	14	13	35	50	M6x10	F05
2"	50	M15x1.5	8.9	11	12.5	35	50	M6x10	F05
2.1/2"	65	M22x1.5	16	13.5	17	55	70	M8x12	F07
3"	80	M24x2	18.2	23	14	55	70	M8x12	F07
*4"	100	M24x1.5	18.2	17	16	55	70	M8x12	F07
*6"	150	Ø 34	26	39	21	70	102	M10x15	F10

\* THE MISURES OF 4" FULL BORE ARE THE SAME OF 6" REDUCED BORE  
 THE MISURES OF 6" FULL BORE ARE THE SAME OF 8" REDUCED BORE

**THE BELOW TABLE REFERS TO AIR TORQUE ACTUATORS**

VALVE SIZE		DOUBLE ACTING ACTUATOR							ACTUATOR TYPE	BRACKET TYPE	ADAPTOR TYPE	
FULL BORE	RED. BORE	DIMENSIONS (mm)										
Inch	DN	Inch	DN	A	B	C	D	E	F			
1/2"	15	-	-	158.5	67	85	20	36	47	AT 101 DA ISO F05-CH14	ST1	A1/B
3/4"	20	-	-	158.5	73	85	20	36	47	AT 101 DA ISO F05-CH14	ST2	A2/B
1"	25	-	-	210.5	73	102	20	42.5	52	AT 201 DA ISO F05/F07-CH14	ST2	A2/B
1.1/4"	32	-	-	210.5	82	102	20	42.5	52	AT 201 DA ISO F05/F07-CH14	ST3	A3/E
1.1/2"	40	-	-	210.5	86	102	20	42.5	52	AT 201 DA ISO F05/F07-CH14	ST3	A3/E
2"	50	-	-	247.5	97	115	20	49.5	56.8	AT 251 DA ISO F05/F07-CH17	ST3	A3/B
2.1/2"	65	-	-	268.5	115	127	20	56	67	AT 301 DA ISO F05/F07-CH17	ST4	A4/G
3"	80	-	-	268.5	132	127	20	56	67	AT 301 DA ISO F05/F07-CH17	ST4	A5/E
4"	100	6"	150	408.5	162.5	177	30	80	91.5	AT 451 DA ISO F10/F12-CH27	BT3	A5/F
6"	150	8"	200	408.5	221	177	30	80	91.5	AT 451 DA ISO F10/F12-CH27	BT4	A6/A

VALVE SIZE		SPRING RETURN ACTUATOR (S10)							ACTUATOR TYPE	BRACKET TYPE	ADAPTOR TYPE	
FULL BORE	RED. BORE	DIMENSIONS (mm)										
Inch	DN	Inch	DN	A	B	C	D	E	F			
1/2"	15	-	-	210.5	67	102	20	42.5	52	AT 201 S10 ISO F05/F07-CH14	ST1	A1/B
3/4"	20	-	-	210.5	73	102	20	42.5	52	AT 201 S10 ISO F05/F07-CH14	ST2	A2/B
1"	25	-	-	247.5	73	115	20	49.5	56.8	AT 251 S10 ISO F05/F07-CH17	ST2	A2/E
1.1/4"	32	-	-	268.5	82	127	20	56	67	AT 301 S10 ISO F05/F07-CH17	ST3	A3/A
1.1/2"	40	-	-	268.5	86	127	20	56	67	AT 301 S10 ISO F05/F07-CH17	ST3	A3/A
2"	50	-	-	268.5	97	127	20	56	67	AT 301 S10 ISO F05/F07-CH17	ST3	A3/B
2.1/2"	65	-	-	345	115	157	30	69.5	82	AT 401 S10 ISO F07/F10-CH22	ST4	A4/A
3"	80	-	-	345	132	157	30	69.5	82	AT 401 S10 ISO F07/F10-CH22	ST4	A5/A
4"	100	6"	150	437.5	162.5	196	30	88	99	AT 501 S10 ISO F10-CH27	BT3	A5/F
6"	150	8"	200	487	221	220.5	50	99	105	AT 551 S10 ISO F12-CH36	BT4	A6/B

**General Remarks:**

- 1 - The above actuators have been selected considering an air supply of 80 psi or 5,6 bar.
- 2 - On spring return actuators the N. of springs per side is 5.
- 3 - For different air supply please see Airtorque Catalogue.
- 4 - Bracket and adaptor are dimensioned to fit Airtorque actuators.
- 5 - When air supply for actuator is lower than 5,6 bar bigger actuator must be selected and bracket plus adaptor become special.

## DESCRIPTION

<b>DESIGN</b>	: TWO PIECES BOLTED CONSTRUCTION - SOLID BALL - ANTI BLOW OUT PROOF STEM DESIGN - ENCAPSULATED SOFT SEATS - ANTISTATIC DEVICE - ISO 5211 ON THE TOP FOR EASY AUTOMATION - FIRE TEST APPROVED.
<b>SIZE</b>	: DN 15-150 FULL BORE                      DN 150-200 REDUCED BORE 1/2"-6" FULL BORE                              6"-8" REDUCED BORE
<b>CLASS</b>	: ASME 150 - 300 LBS or PN 16 - 25 - 40
<b>MATERIALS</b>	: ASTM A105 - LF2 - 316 AND SPECIAL MATERIALS
<b>CONSTRUCTION</b>	: ASME B16.34 - BS5351 - API6D
<b>MARKING</b>	: MSS SP25
<b>CE 0038</b>	: ACCORDING TO DIRECTIVE 97/23/CE - MODULE H CATEGORY III - NOTIFIED BODY LLOYD'S REGISTERED CERTIFICATE NR. RPS 01060304/01
<b>Ex IM2/II 2GD</b>	: ACCORDING TO ATEX 94/9 CE - TECHNICAL FILE NR. ST01 ATEX
<b>TEST CERTIFICATE</b>	: UNI EN 10204 TYPE 3.1B UNLESS OTHERWISE REQUIRED
<b>FIRE TEST APPROVED</b>	: BS6755 PART 2 - API607 - API6FA
<b>SERVICE</b>	: FOR PETROLEUM, CHEMICALS, PETROLCHEMICALS AND ALLIED INDUSTRIES

## MAX. WORKING PRESSURE AND PRESSURE TEST OF VALVES VALUES FROM API 6D - API 6A

PRESSURE CLASS OF VALVE			ANSI 150	ANSI 300	PN 16	PN 25	PN 40	For temperatures below -20°F or -29°C the rating shall be no greater than the rating shown for -20°F or -29°C.
MAXIMUM OPERATING PRESSURE	-29 to 38°C	Bar	19	49.6	16	25	40	
	-20 to 100°C	Psig Kpa	275 1900	720 4960	232 1600	363 2500	580 4000	
PRESSURE TEST (1)	HYDROSTATIC SHELL TEST	Bar Psig	29 425	76 1100	25 363	40 580	60 870	DURATION TEST 2 minutes
	HYDROSTATIC SEATS TEST	Bar Psig	21 300	55 800	18 261	28 406	44 638	2 minutes
	AIR SEATS TEST	Bar±1 Psig±10	6 80	6 80	6 80	6 80	6 80	2 minutes

(1) Non visible leakage under all test pressures sequence.

1 bar=100Psig 1 Psig=0,06894757 bar 1 bar=14.5 Psig The test pressure listed above are not valve operating pressure.

## FLOW DATA

The following flow rates were determined for ball valves in fully open position and a water temperature of 60°F (15°C).

Kv value is the full capacity flow rate through the ball valve in cubic metres per hour (m³/h) with a pressure drop of 1 bar.

Cv value is the full capacity flow rate through the ball valve in gallons/min of water at 60°F with a pressure drop of 1psi.

VALVE SIZE	1/2"	3/4"	1"	1.1/4"	1.1/2"	2"	2.1/2"	3"	4"	6"
Cv	12	30	45	78	115	265	445	680	1989	4797
Kv	10	26	38	67	99	227	381	583	1700	4100

## DIFFERENT CONFIGURATIONS

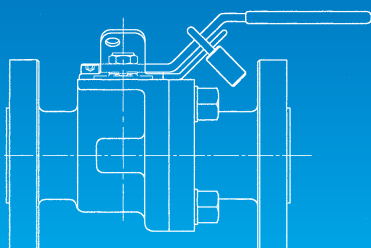

LOCKING DEVICE

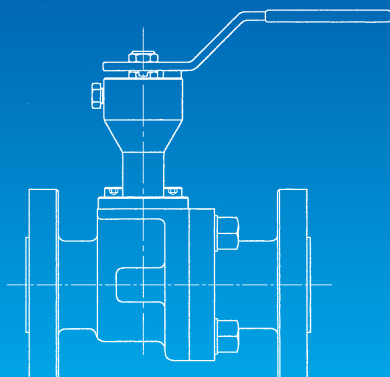

FUGITIVE EMISSION

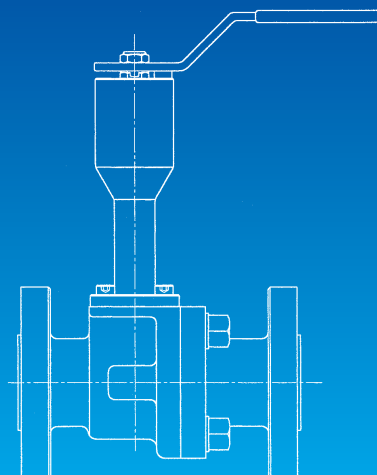

EXTENSION STEM

## **SALES ORGANIZATION**



### **MAIN DISTRIBUTORS**

**Norway, Sweden, Denmark, Netherlands,  
Belgium, Switzerland, Austria, Greece,  
Brasil, Usa, Canada, Australia, New Zeland, South Africa,  
UAE, Czech Republic, Slovakia, Poland  
Singapore, Romania, Oman, Saudi Arabia, Kuwait**

#### **STARLINE S.p.A.**

“one man company”

Via F. Baracca, 30 - 24060 S. PAOLO D'ARGON (Bergamo) ITALY

Phone: 0039 035/958041/958102 - Fax: 0039 035/958413 - <http://www.starline.it> - e-mail: [starline@starline.it](mailto:starline@starline.it)

**STARLINE BALL VALVES LTD**  
Telford Way Stephenson Ind. Est.  
Coalville Leicestershire LE 67 3HE  
Great Britain  
Phone: 0044 (0)1530815818  
Fax: 0044 (0)1530815819  
<http://www.acvalvealliance.com>  
e-mail: [Starline@acvalvealliance.com](mailto:Starline@acvalvealliance.com)

**STARLINE FRANCE**  
7, Parc d'Activités  
de la Verdière 1  
13880 VELAUX - France  
Phone: 0033 (0)442878400  
Fax: 0033 (0)442878404  
<http://www.star-line.fr>  
e-mail: [infos@star-line.fr](mailto:infos@star-line.fr)

**STARLINE IBERICA S.A.**  
Poligono Industrial El Circuit  
C/Rec Del Molinar F-3  
08160 Montmelò Barcelona - Spain  
Phone: 0034 935799370  
Fax: 0034 935799244  
<http://www.starline.es>  
e-mail: [starline@starline.es](mailto:starline@starline.es)

**STARLINE VALVES OY**  
Martinkyläntie, 39  
01720 Vantaa - Finland  
Phone: 0035 898787711  
Fax: 0035 898787221  
<http://www.starline.fi>  
e-mail: [starline@starline.fi](mailto:starline@starline.fi)

**STARLINE Armaturen GmbH**  
Industriestrasse, 25  
64569 Nauheim - Germany  
Phone: 0049 (0)6152987655  
Fax: 0049 (0)6152987656  
e-mail: [starline.gmbh@t-online.de](mailto:starline.gmbh@t-online.de)

**Your Representative:**